

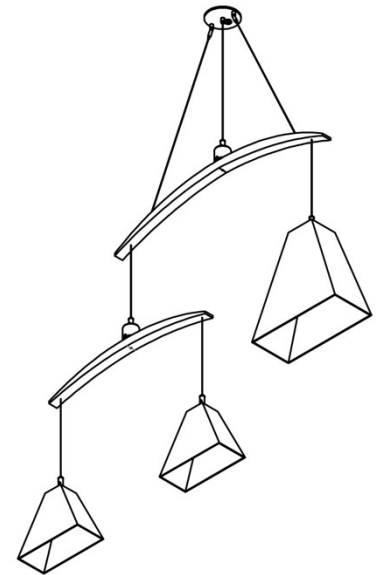

The artful and alluring decorative **Balance Light** is designed as a modular and mobile unit that can be adapted for commercial and residential spaces. This 3-Light Mobile fixture features 1-Large and 2-Small slip-cast porcelain pendant shades suspended from handcrafted reclaimed hardwood bows. Standard features include a black fabric power cord with aircraft cable reinforcement and satin black steel hardware. The exterior of each shade is matte (unglazed), and the interior has a clear gloss finish.

HARDWARE ASSEMBLY

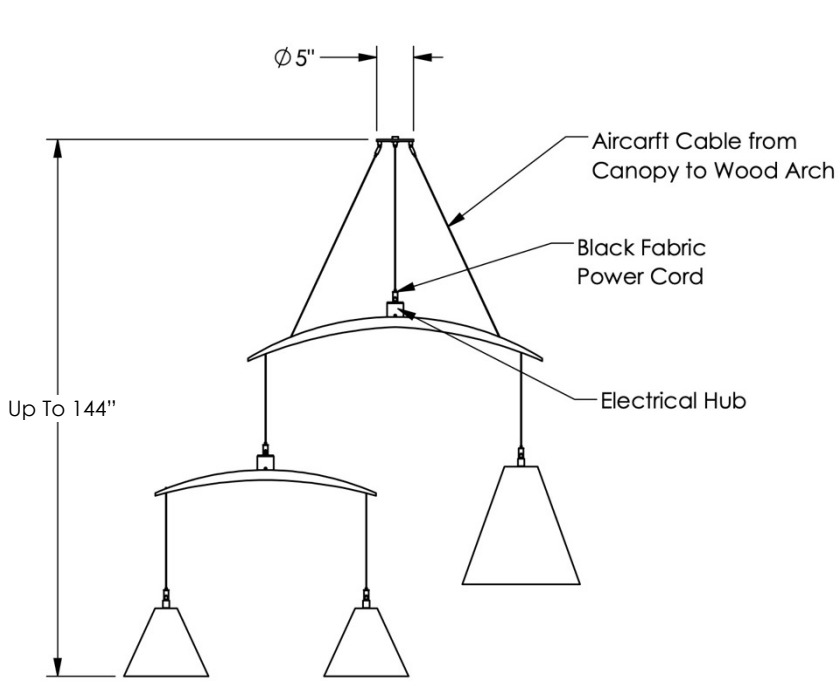



Balance Light 3-Light Mobile, First Generation Design for Balance Restaurant, Springboard Design Architects

MADE IN THE U.S.A.

- Produced by Stak Ceramics
- Manufacturing in Pittsburgh, PA
- Hardware assembly in Derry, PA

FEATURES & BENEFITS

- 3-Light Mobile responds with movement (airflow)
- Raw (matte) porcelain pendant shades with clear gloss glazed interior
- Wood bows are made from reclaimed hardwood cut-offs (species varies unless specified by order)
- Suitable for interior dry applications
- UL Listed, Dimmable LED Module or Medium Socket options
- Lead time: approx. 6-10 weeks

TECHNICAL INFORMATION

- 3-Light Mobile: approx. 72"W x 40"D x 32"H; Up to 144" Total Light Length; 5" Canopy

FINISH OPTIONS

- Select Dimmable LED Module or Medium Socket
- Specify total light length upon order
- Custom wood species and finish options available

CARE & MAINTENANCE

- Shipped using recycled packaging
- Installation instructions provided

ABOUT THE PRODUCER

Established 2011, **Stak Ceramics** is recognized for thoughtfully designed home goods. A creative collaboration between partners Myles Geyman and Heather Connolly, Stak offers expert knowledge of ceramic design and fabrication. Monmade is proud to showcase Stak's creative expansion into commercial lighting and décor products.

Stak is headquartered at **7800 Susquehanna**, a renovated factory space that serves as a hub for manufacturing, makers, small businesses, non-profits, and job training in Pittsburgh's Homewood neighborhood.

SUSTAINABILITY & CERTIFICATIONS

UL Listed, LED compliant

Compliance with LEED V4 credits:

Interior Environmental Quality, Interior Lighting
Regional Priority Materials & Resources

Meets sustainably **Monmade** Dimensions



- 50% woman-owned creative business
- Ceramic components are manufactured headquarters in a repurposed industrial facility located in a low- or moderate-income area; energy use reduction is a priority in the facility
- Waste materials from the manufacturing process are recycled into new product; water is reused within the manufacturing process
- Glazing materials sprayed on as coloring agents are either natural, low-to-no-zero VOC
- Hardware bow component utilizes reclaimed wood
- Balance Light is made in collaboration with supporting lighting manufacturer located within a 35-mile radius of SPACAPAN's primary facility; this EPA compliant manufacturer provides hardware assembly and certifies the product to UL Listed standards

[Learn more](#) about Monmade's holistic approach to sustainability.